



2118 Wilshire Blvd., #550
 Santa Monica, CA 90403
 888-888-2358 fax 888-333-2358
 mike@beltlink.com

ROUND WIRE BELT SPECIFICATION FORM

COMPANY NAME:		ATTENTION:	
COMPANY ADDRESS:		SPECIAL REQUIREMENTS:	
EMAIL ADDRESS:		(ex. PIN ROLL OR SPROCKET DRIVE)	
TEL NO.:			
FAX NO.:			

BELT SPECIFICATION	
BELT WIDTH	
BELT LENGTH	
BELT MATERIAL	
EDGE FINISH	
BELT STYLE	B or BFS
SP	
SD	
CP	
CD	
*FW	
*FT	

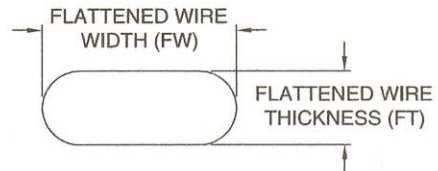
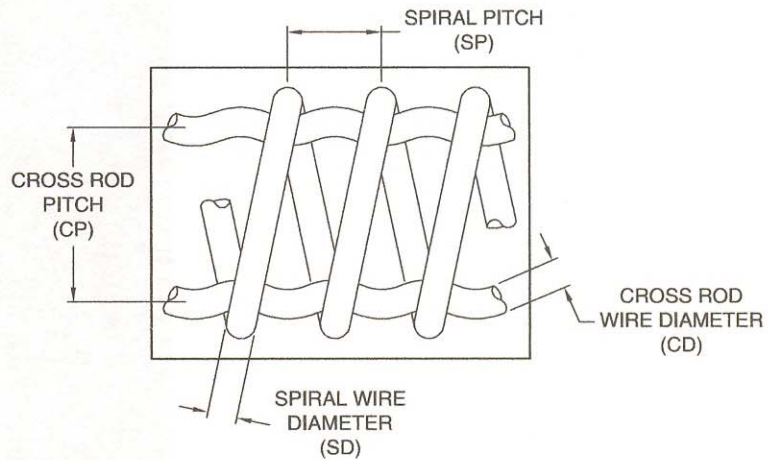

SPIRAL & CROSS ROD PITCH MEASURING

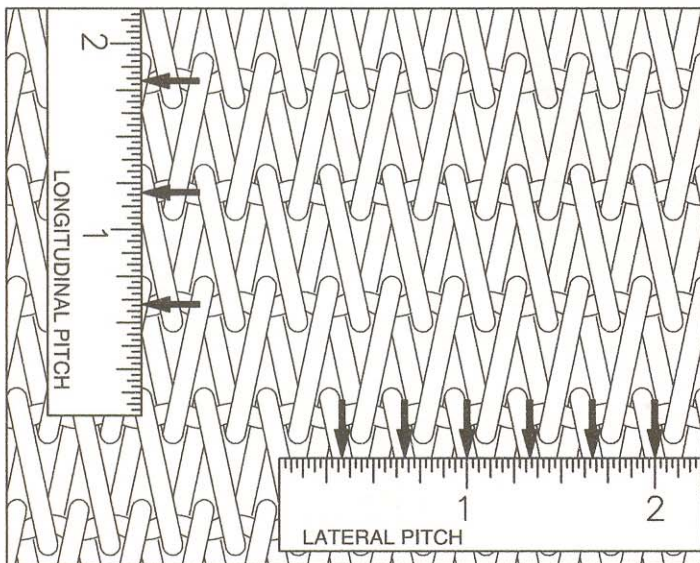

MESH DESIGNATION

ex. B-36-20-12

LETTER DESIGNATION = BELT STYLE, WHETHER BALANCE WEAVE (B) OR BALANCE WEAVE FLATTENED SPIRAL (BFS)

1ST COUNT = NUMBER OF LOOPS IN 12 INCHES OF BELT WIDTH = LATERAL PITCH

2ND COUNT = NUMBER OF CONNECTOR RODS IN 12 INCHES OF BELT LENGTH = LONGITUDINAL PITCH

3RD COUNT = WIRE GAUGE. IF 3RD COUNT CONSISTS OF (2) PAIRS OF NUMBERS, THE 1ST IS THE CONNECTOR WIRE GAUGE, THE 2ND IS THE SPIRAL WIRE GAUGE.

*ONLY DIMENSIONAL REQUIREMENTS FOR BFS STYLE BELT